

Wednesday 11 January 2012 – Morning

GCSE MATHEMATICS SYLLABUS A

J512/03 Paper 3 (Higher Tier)

Candidates answer on the Question Paper.

OCR supplied materials:
None

Other materials required:

- Geometrical instruments
- Tracing paper (optional)

Duration: 2 hours



Candidate forename		Candidate surname	
--------------------	--	-------------------	--

Centre number						Candidate number				
---------------	--	--	--	--	--	------------------	--	--	--	--

INSTRUCTIONS TO CANDIDATES

- Write your name, centre number and candidate number in the boxes above. Please write clearly and in capital letters.
- Use black ink. HB pencil may be used for graphs and diagrams only.
- Answer **all** the questions.
- Read each question carefully. Make sure you know what you have to do before starting your answer.
- Show your working. Marks may be given for a correct method even if the answer is incorrect.
- Write your answer to each question in the space provided. Additional paper may be used if necessary but you must clearly show your candidate number, centre number and question number(s).
- Do **not** write in the bar codes.

INFORMATION FOR CANDIDATES

- The number of marks is given in brackets [] at the end of each question or part question.
- The total number of marks for this paper is **100**.
- This document consists of **24** pages. Any blank pages are indicated.



This paper has been pre modified for carrier language

Formulae Sheet: Higher Tier

Area of trapezium = $\frac{1}{2}(a + b)h$

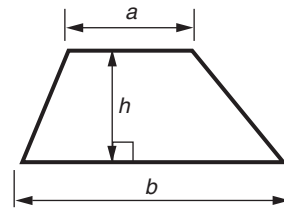

Volume of prism = (area of cross-section) \times length

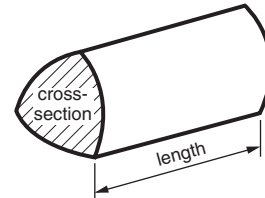

In any triangle ABC

Sine rule $\frac{a}{\sin A} = \frac{b}{\sin B} = \frac{c}{\sin C}$

Cosine rule $a^2 = b^2 + c^2 - 2bc \cos A$

Area of triangle = $\frac{1}{2}ab \sin C$

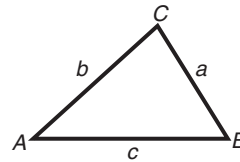

Volume of sphere = $\frac{4}{3}\pi r^3$

Surface area of sphere = $4\pi r^2$

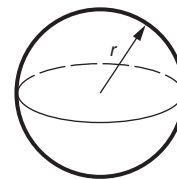

Volume of cone = $\frac{1}{3}\pi r^2 h$

Curved surface area of cone = $\pi r l$

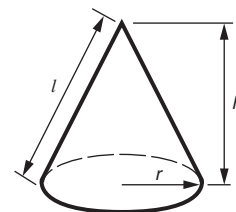

The Quadratic Equation

The solutions of $ax^2 + bx + c = 0$,
where $a \neq 0$, are given by

$$x = \frac{-b \pm \sqrt{b^2 - 4ac}}{2a}$$

PLEASE DO NOT WRITE ON THIS PAGE

1

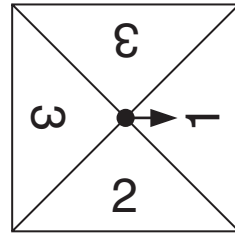
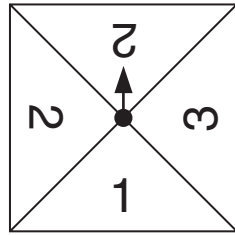

Two fair spinners are numbered 1, 2, 2, 3 and 1, 2, 3, 3. The spinners are spun and the scores added.

(a) Complete the table to show the possible totals.

	1	2	2	3
1	2			
2	3	4		
3				
3				

[2]

(b) Work out the probability of getting a total of 5.

.....

.....

(b) _____ [2]

(c) Work out the probability of getting the same score on both spinners.

.....

.....

(c) _____ [1]

- 2 The table shows the ingredients needed to make vegetable soup for 4 people.

Vegetable soup (Serves 4 people)	
Vegetables	600 g
Stock	400 ml
Oil	3 tablespoons
Garlic	2 cloves

- (a) What weight of vegetables is needed to make vegetable soup for 3 people?

.....

(a) _____ g [1]

- (b) How many tablespoons of oil are needed to make vegetable soup for 6 people?

.....

(b) _____ [1]

- (c) Matt has only 1 litre of stock.
 He has plenty of the other ingredients.

What is the maximum number of people he can make vegetable soup for?

.....

(c) _____ [2]

- 3 In the diagram, ABC is parallel to DEF and BEG is parallel to ADH .
Angle $EDH = 66^\circ$ and angle $EAD = 34^\circ$.

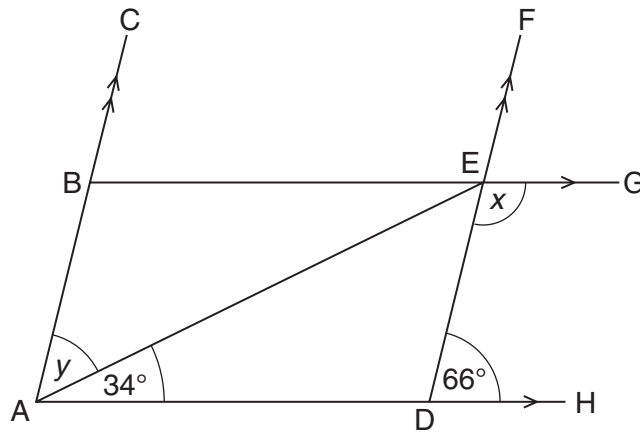

NOT TO
SCALE

- (a) Work out the size of angle x .
Give a reason for your answer.

.....
.....

Angle $x =$ _____ $^\circ$ because _____

_____ [2]

- (b) Work out the size of angle y .
Give a reason for your answer.

.....
.....

Angle $y =$ _____ $^\circ$ because _____

_____ [2]

- 4 Tom's take home pay is £205 per week.
He gives $\frac{2}{5}$ of this to his mother.
He saves 15% of the remainder.

How much of his pay does he have left to spend?

.....

.....

.....

.....

.....

.....

.....

.....

£ _____ [6]

5 (a) Solve.

(i) $2(3x + 7) = 26$

.....

.....

.....

.....

(a)(i) _____ [3]

(ii) $5x - 7 = 3x + 2$

.....

.....

.....

.....

(ii) _____ [3]

(b) (i) Solve.

$2x - 1 \geq -5$

.....

.....

.....

.....

(b)(i) _____ [2]

(ii) Show your solution to part (b)(i) on the number line below.

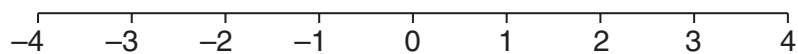

[1]

6 The table shows the lengths and weights of nine guinea pigs.

Length (cm)	15.2	15.5	15.8	15.8	16.0	17.0	17.5	17.8	18.0
Weight (g)	62	63	64	62	62	65	70	66	67

- (a) Complete the scatter diagram.
The first five points have already been plotted.

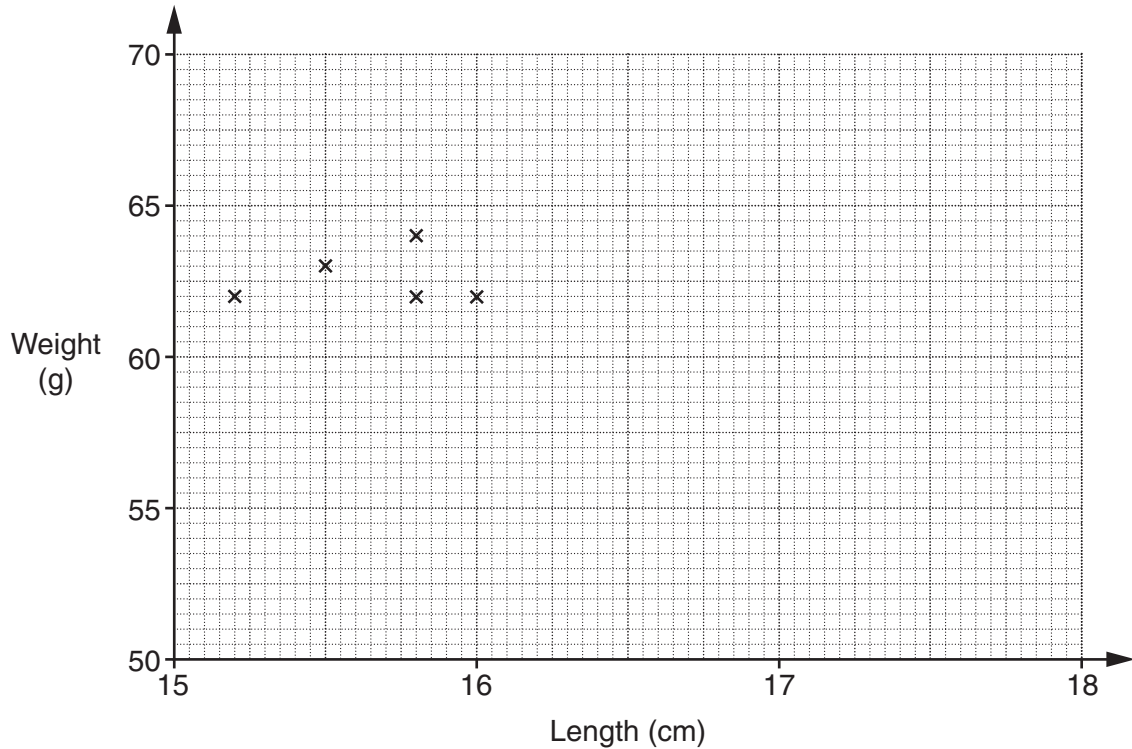

[2]

- (b) Describe the correlation shown in the diagram.

(b) _____ [1]

- (c) Draw a line of best fit on your diagram.

[1]

- (d) Another guinea pig is 16.5 cm long.

Use your line of best fit to estimate its weight.

(d) _____ g [1]

- (e) Jill says 'If I could extend the horizontal axis and the line of best fit I could estimate the weight of a guinea pig which is 22 cm long'.

Explain why it would not be sensible for Jill to do this.

_____ [1]

7 Work out.

(a) $\sqrt{10^3 - 4 \times 15^2}$

.....

.....

.....

.....

(a) _____ [3]

(b) $\frac{3}{4} \div \frac{7}{8}$

Give your answer as a fraction in its simplest form.

.....

.....

.....

.....

(b) _____ [2]

8 You are given that

$$-5 \leq x \leq 3 \quad \text{and} \quad -7 \leq y \leq 4.$$

Work out

(a) the largest value of x^2 ,

.....

(a) _____ [1]

(b) the smallest value of $x + y$,

.....

(b) _____ [1]

(c) the largest value of $y - x$,

.....

(c) _____ [1]

(d) the smallest value of xy .

.....

(d) _____ [2]

9 A triangular prism has dimensions as shown in the diagram.

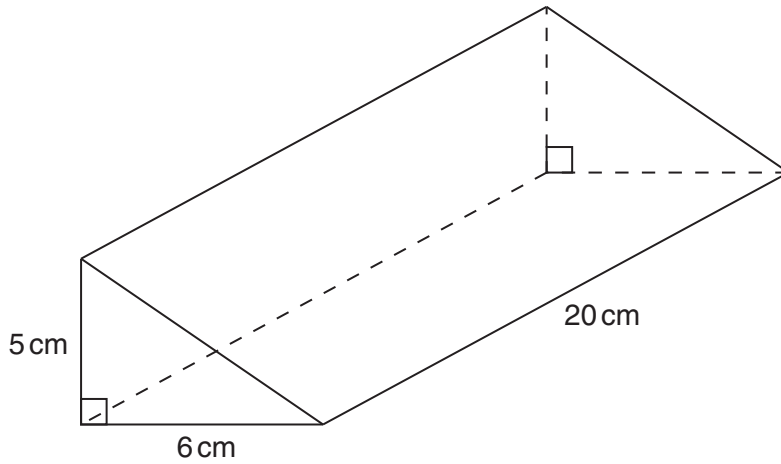

(a) Work out the volume of the prism.

.....

.....

.....

.....

(a) _____ cm³ [3]

(b) The prism weighs 750g.

Work out the density of the material.
Give the units of your answer.

.....

.....

.....

.....

(b) _____ [3]

- 10 ABC is the outline of the logo used by a company on its business letters.
 A logo PQR, that is mathematically similar to ABC, is used on the side of its delivery vans.

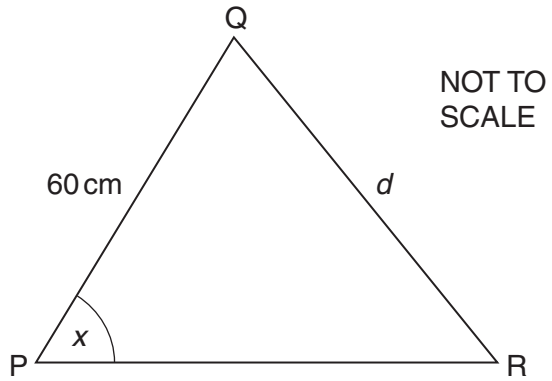
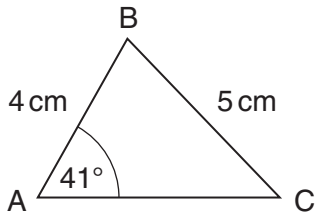

- (a) What is the size of angle x ?

(a) _____ $^\circ$ [1]

- (b) Work out the length d .

.....

.....

.....

.....

(b) _____ cm [3]

11 In each part of this question, O is the centre of the circle.

(a)

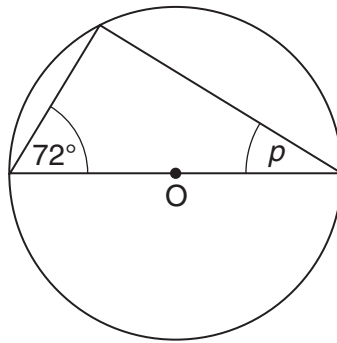

NOT TO SCALE

Work out the size of angle p .
Give geometrical reasons for your answer.

.....

.....

$p =$ _____ $^{\circ}$ because _____

_____ [2]

(b)

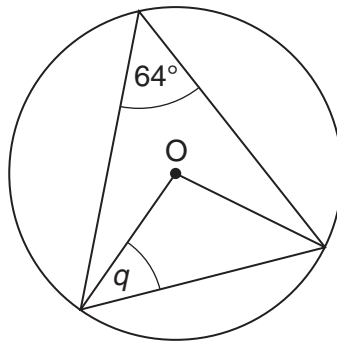

NOT TO SCALE

Work out the size of angle q .

.....

.....

.....

.....

(b) _____ $^{\circ}$ [3]

12 The box plot represents the distribution of the speeds, in km/h, of vehicles on a road during the daytime.

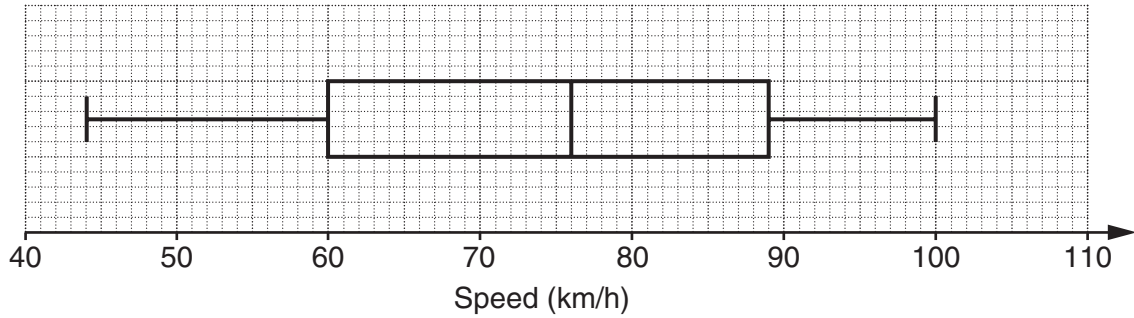

(a) (i) What is the median speed?

(a)(i) _____ km/h [1]

(ii) Work out the interquartile range of the speeds.

.....

(ii) _____ km/h [2]

This box plot represents the distribution of the speeds, in km/h, of vehicles on the same road at night.

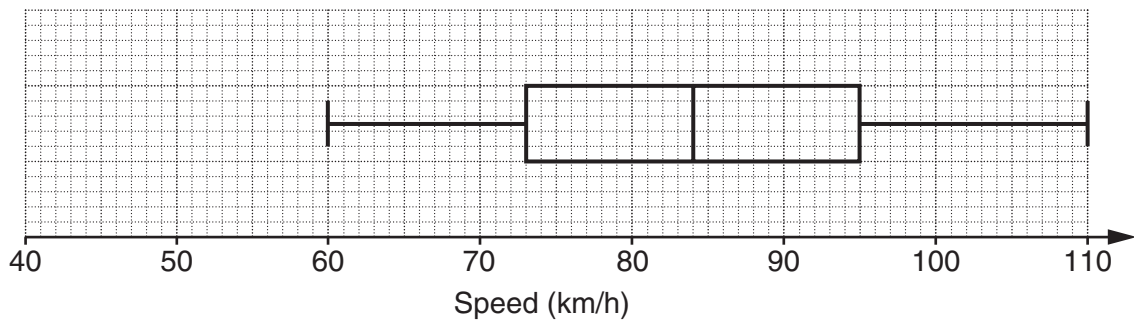

(b) Make two comparisons between the speeds of vehicles during the daytime and at night.

(1) _____

(2) _____

_____ [2]

- 13 The diagram shows a right-angled triangle.
All lengths are in centimetres.

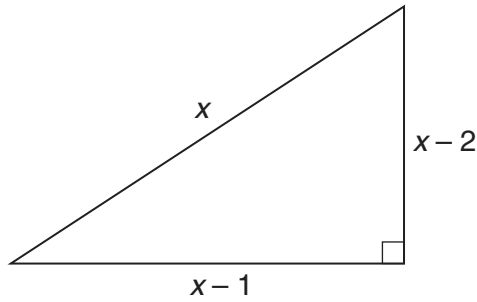

- (a) Show that $x^2 - 6x + 5 = 0$.

.....

.....

.....

.....

.....

.....

.....

.....

(a) _____ [4]

- (b) Solve $x^2 - 6x + 5 = 0$ and hence find the lengths of the sides of the triangle.

.....

.....

.....

.....

.....

.....

.....

.....

(b) _____ cm _____ cm _____ cm [4]

15 Triangle **B** is an enlargement of triangle **A**.

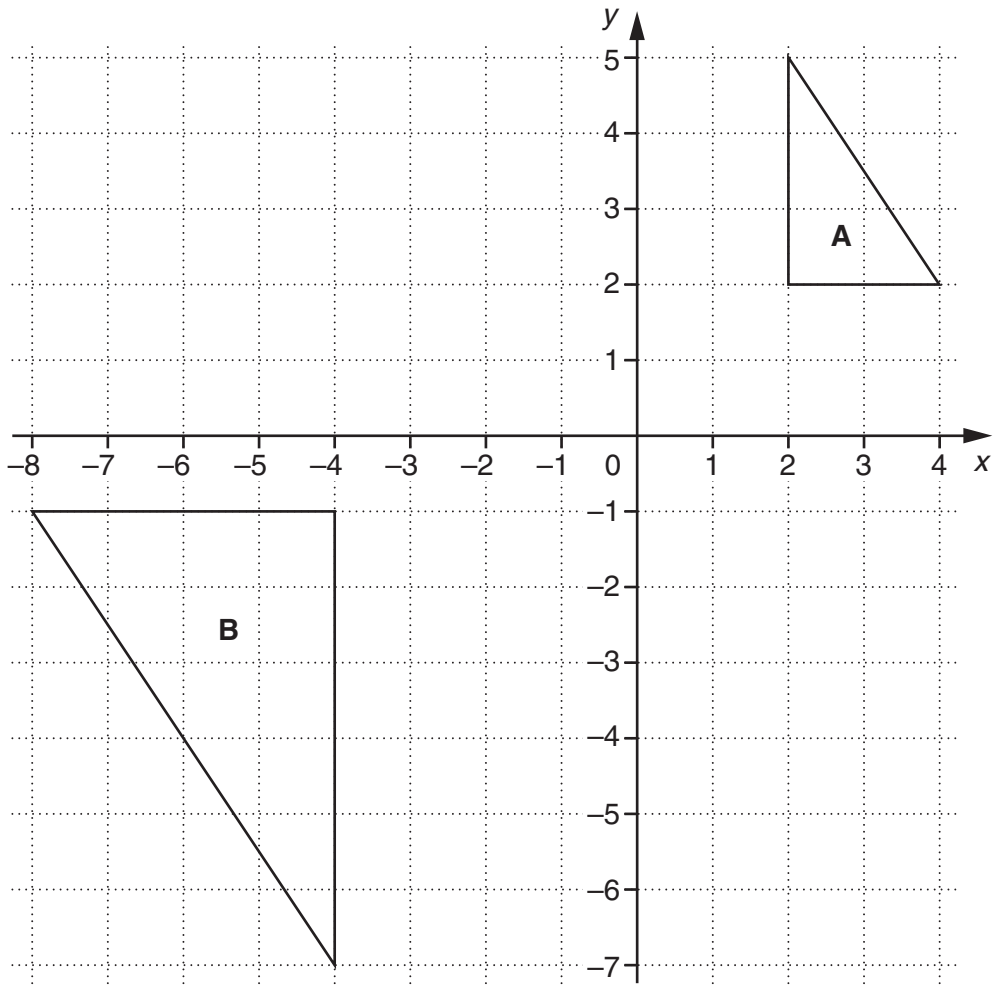

(a) What is the scale factor of the enlargement?

.....

(a) _____ [2]

(b) What are the coordinates of the centre of the enlargement?

.....

(b) _____ [2]

16 The force, F , between two masses is **inversely** proportional to R^2 , the square of the distance between them.

(a) Given that F is 8 when R is 5, find a formula for F in terms of R .

.....
.....
.....
.....
.....
.....
.....

(a) _____ [3]

(b) Find F when R is $\frac{1}{2}$.

.....
.....
.....
.....
.....

(b) _____ [2]

17 (a) Simplify.

(i) $5\sqrt{2} - 2\sqrt{2}$

.....

(a)(i) _____ [1]

(ii) $\sqrt{3} \times \sqrt{12}$

.....

(ii) _____ [2]

(b) Evaluate.

(i) $125^{\frac{1}{3}}$

.....

(b)(i) _____ [1]

(ii) $25^{-\frac{1}{2}}$

.....

(ii) _____ [2]

18 Write $x^2 + 8x - 1$ in the form $(x + c)^2 + d$.

.....

.....

.....

.....

.....

_____ [3]

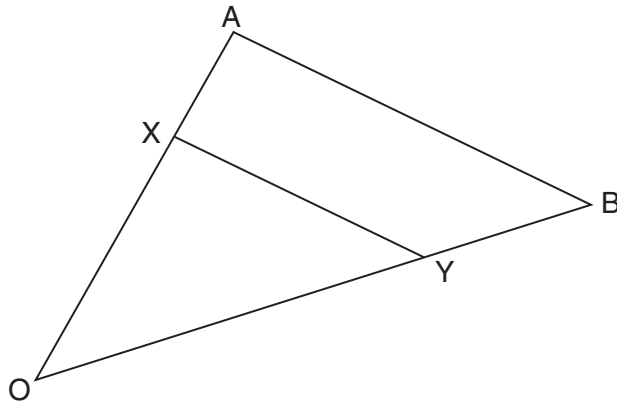

NOT TO SCALE

In the diagram, $\vec{OA} = 2\mathbf{a}$ and $\vec{OB} = 2\mathbf{b}$.
 X is a point on OA such that OX : XA is 3 : 1.
 Y is a point on OB such that OY : YB is 3 : 1.

(a) Find, in terms of \mathbf{a} and \mathbf{b} ,

(i) \vec{AB} ,

.....

(a)(i) _____ [1]

(ii) \vec{XY} .

.....

(ii) _____ [2]

(b) State two facts about the relationship between the lines AB and XY.

(1) _____

(2) _____
 _____ [2]

BLANK PAGE

PLEASE DO NOT WRITE ON THIS PAGE

BLANK PAGE

PLEASE DO NOT WRITE ON THIS PAGE

PLEASE DO NOT WRITE ON THIS PAGE



Copyright Information

OCR is committed to seeking permission to reproduce all third-party content that it uses in its assessment materials. OCR has attempted to identify and contact all copyright holders whose work is used in this paper. To avoid the issue of disclosure of answer-related information to candidates, all copyright acknowledgements are reproduced in the OCR Copyright Acknowledgements Booklet. This is produced for each series of examinations and is freely available to download from our public website (www.ocr.org.uk) after the live examination series.

If OCR has unwittingly failed to correctly acknowledge or clear any third-party content in this assessment material, OCR will be happy to correct its mistake at the earliest possible opportunity.

For queries or further information please contact the Copyright Team, First Floor, 9 Hills Road, Cambridge CB2 1GE.

OCR is part of the Cambridge Assessment Group; Cambridge Assessment is the brand name of University of Cambridge Local Examinations Syndicate (UCLES), which is itself a department of the University of Cambridge.